

52

FULTON STREET FINANCIAL DISTRICT, NYC

Corner of Fulton & Cliff Streets

RETAIL/RESTAURANT FOR LEASE

APPROXIMATE SIZE

Ground Floor: 2,200 SF
2nd Floor: 2,200 SF

POSSESSION

Immediate

ASKING RENT

Ground Floor: \$24,000/Month
2nd Floor: \$11,000/Month

TERM

10+ Years

FRONTAGE

56 FT Wraparound

COMMENTS

- Second generation restaurant on the ground floor
- Full brand-new kitchen with gas and venting in place
- Floors can be leased together or separately
- 24/7 foot traffic steps from the Seaport and close proximity to Fulton Street subway station

NEIGHBORS

Hey Thai • Carvel • Orange Theory • Harry's Italian • Felice • Orange Theory • Chop & Go • Taco Bell • Stout • Pearl Diner • Playa Bowls

TRANSPORTATION

2 3 4 5 ACEJZ



JAMES FAMULARO
President

JOHN ROESCH
Director
212.468.5971
jroesch@meridiancapital.com

SARA LAMSTEIN
Associate
212.468.5945
slamstein@meridiancapital.com



MERIDIAN
RETAIL LEASING

All information supplied is from sources deemed reliable and is furnished subject to errors, omissions, modifications, removal of the listing from sale or lease, and to any listing conditions, including the rates and manner of payment of commissions for particular offerings imposed by Meridian Capital Group. This information may include estimates and projections prepared by Meridian Capital Group with respect to future events, and these future events may or may not actually occur. Such estimates and projections reflect various assumptions concerning anticipated results. While Meridian Capital Group believes these assumptions are reasonable, there can be no assurance that any of these estimates and projections will be correct. Therefore, actual results may vary materially from these estimates and projections. Any square footage dimensions set forth are approximate.



INTERIOR

JAMES FAMULARO
President

JOHN ROESCH
Director
212.468.5971
jroesch@meridiancapital.com

SARA LAMSTEIN
Associate
212.468.5945
slamstein@meridiancapital.com



MERIDIAN
RETAIL LEASING

52 FULTON STREET

FINANCIAL DISTRICT, NYC | Corner of Fulton and Cliff Streets

RETAIL/RESTAURANT FOR LEASE

FLOOR PLAN | GROUND FLOOR

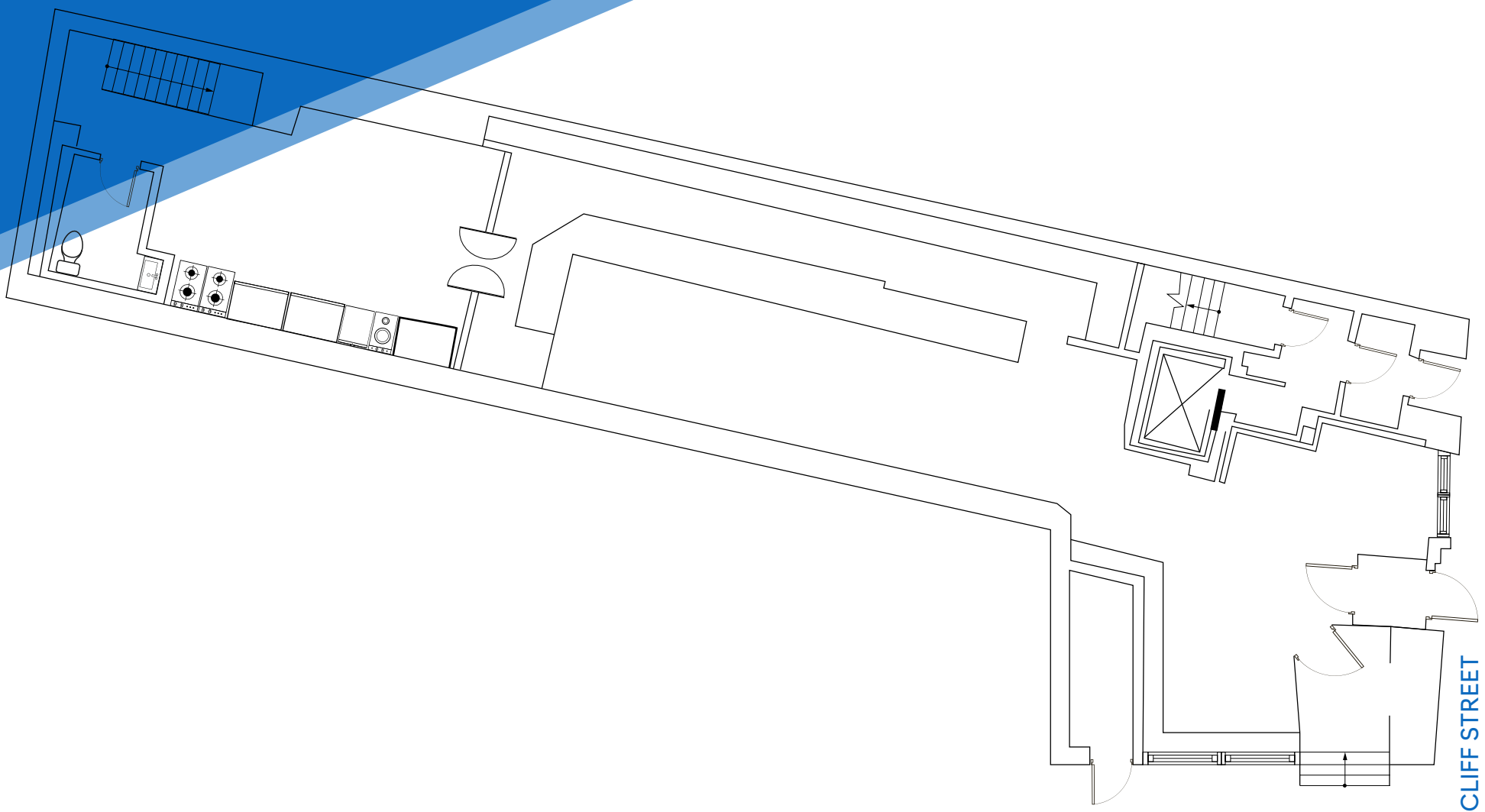

FULTON STREET

CLIFF STREET

JAMES FAMULARO
President

JOHN ROESCH
Director
212.468.5971
jroesch@meridiancapital.com

SARA LAMSTEIN
Associate
212.468.5945
slamstein@meridiancapital.com



MERIDIAN
RETAIL LEASING

All information supplied is from sources deemed reliable and is furnished subject to errors, omissions, modifications, removal of the listing from sale or lease, and to any listing conditions, including the rates and manner of payment of commissions for particular offerings imposed by Meridian Capital Group. This information may include estimates and projections prepared by Meridian Capital Group with respect to future events, and these future events may or may not actually occur. Such estimates and projections reflect various assumptions concerning anticipated results. While Meridian Capital Group believes these assumptions are reasonable, there can be no assurance that any of these estimates and projections will be correct. Therefore, actual results may vary materially from these estimates and projections. Any square footage dimensions set forth are approximate.



NEIGHBORS

JAMES FAMULARO
 President

JOHN ROESCH
 Director
 212.468.5971
 jroesch@meridiancapital.com

SARA LAMSTEIN
 Associate
 212.468.5945
 slamstein@meridiancapital.com



MERIDIAN
 RETAIL LEASING